

Recommended Installation Instructions

NATUREPLANK

General Guidelines

- All installation of Natureplank branded LVT products must be done in accordance with the Australian Standard AS1884:2012 and also in accordance with the manufacturer's instructions.
- Please inspect product prior to installation for any visible defects. Do not install any planks that display any imperfections or that do not lie perfectly flat or straight.
- Natureplank vinyl planks are temperature sensitive and should only be installed in a temperature band between 15° C and 28° C.
- Planks need to be conditioned within the installation area for a period not less than 24 hours or until such time as the product has achieved an ambient room temperature range of 15 to 28oC.
- After installation this same approximate temperature needs to be maintained for a period of 24 hours to ensure the adhesive achieves full bond strength.
- Ensure all windows are fully covered with window coverings or black plastic for 48 hours during and after installation.

Site Inspection and Preparation

- All subfloors should be prepared in accordance with AS1884:2012.
- Installation should be carried out on a clean, dry, solid and level subfloor free from cracks and holes.
- Roughness or unevenness in the subfloor may transmit through to the new floor resulting in an unsightly floor surface and causing excessive wear.

Concrete Subfloor Preparation

- The concrete subfloor shall be finished off to specification and in accordance with good business practice.
- The relative humidity of the concrete subfloor must not exceed 75% using the in-situ probe test, taken in accordance with ASTM F2170, or 70% if using the surface mounted insulated hood test, taken in accordance with ASTM F2420.
- Excessive humidity will prevent the adhesive reaching full cure and could remain tacky and accordingly fail to reach full bond strength. A failure to reach bond strength will result in the planks or tiles peaking in heat or gapping in cold conditions. These events would

not constitute a product fault and would not be covered by the warranty.

- High Alkalinity in concrete subfloors will also prevent the adhesive from reaching a full cure with the same consequences as excessive humidity.
- A reading of up to pH10 is acceptable if tested in accordance with Appendix B of AS1884:2012. Do NOT install where pH readings exceed this without prior written consent from Kenbrock.
- The surface of a concrete subfloor shall be thoroughly checked for the following:

Plainness When a straightedge 2000mm long is placed at rest at two points 2000mm apart, no part of the surface shall be more than 4mm below the straightedge.

Smoothness When a straightedge 150mm long is placed at any position at rest at two points on the surface, no part of the surface shall be more than 1mm below the straightedge.

Soundness The surface shall be without cracks, crazing, dusting, rain damage, spalling, efflorescence or blistering.

- The area should be carefully prepared and free from any dirt, cement laitance, cleaning products or any other foreign material.
- New concrete subfloors must be dry and fully cured before applying any screed. Please follow the recommended instructions provided by the screed manufacturer.

Existing Subfloor Preparation

- Existing resilient sheet, LVT or cushion vinyl are not considered a suitable surface for adhering new resilient floor coverings.
- Remove any existing floor coverings and prepare the subfloor in accordance with AS1884:2012.
- When installing over ceramic tiles a levelling compound should be used to smooth out any grout joints.
- When installing over timber floors a hardboard or ply overlay will be required if the existing floor does not comply with AS1884:2012. The hardboard or ply overlay must comply with the standards referenced in AS1884:2012.

Adhesive

Kenbrock recommends the use of Kenbrock Evagrip adhesive with all Natureplank LVT products sold.

Evagrip has been specifically formulated for use with Natureplank LVT products installed within Australia's variable climate. Important notice for installers: Lay tiles and planks in wet adhesive for maximum bond strength.

Also paddle stir the adhesive before use!

Use of other adhesives may invalidate the product warranty, except in the following circumstances:

Note: RLA R555 2 Part Flexible Polyurethane Adhesive must be used in localised areas subject to excessive heat and direct sunlight, e.g. parts of family or lounge rooms with large window fronts, shop windows, patio doors and around fixed room heaters.

RLA R555 2 Part Flexible Polyurethane Adhesive is also recommended if the floor is being installed in a wet area which may be subject to pooled water for lengthy periods, or an area where heavy cleaning is envisaged. Refer to the adhesive manufacturer's product data sheet before commencing installation and apply the adhesive in accordance with their published instructions.

Failure to adhere to these instructions may invalidate the product warranty.

Measuring and Planning the Installation

- Establish the centre point of your room and mark a chalk line A-B through this point parallel to the longest wall.
- Loose lay the planks away from the centre line A-B and check at the perimeter the size of the edge pieces. If they are too small, adjust the size of the edge pieces and adjust the centre to the A-B line.
- From the other wall, mark another chalk centre line C-D, ensuring it is square to the A-B line. The C-D line should be the shorter of the two lines unless the room is a perfect square.
- Mark two chalk lines, E-F & G-H, 305mm either side of the C-D line, making sure these lines are also square to the A-B line. Please note that 305mm corresponds with one-third the length of Floorworks planks.

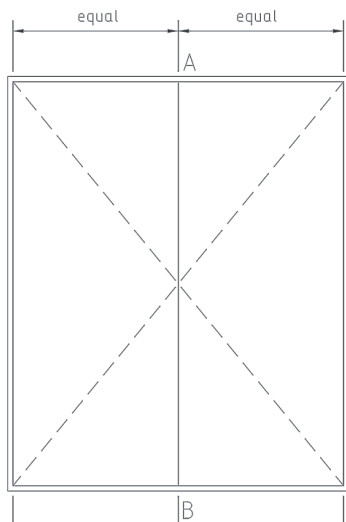

Diagram 1

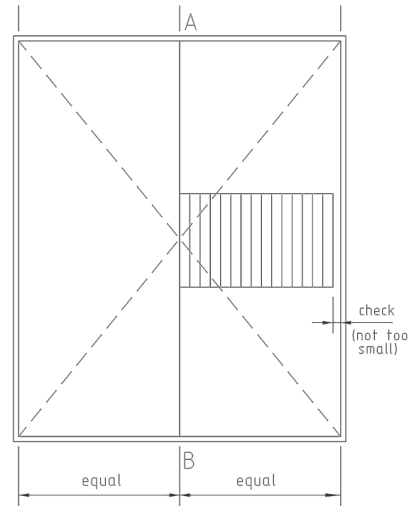

Diagram 2

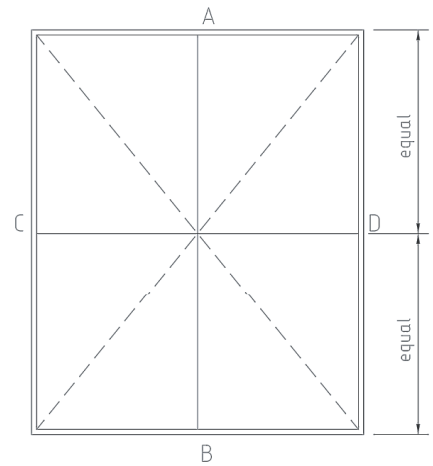

Diagram 3

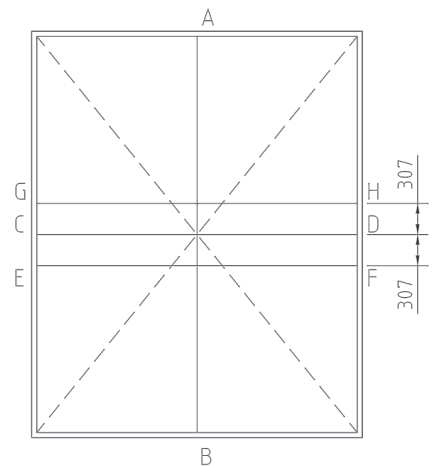

Diagram 4

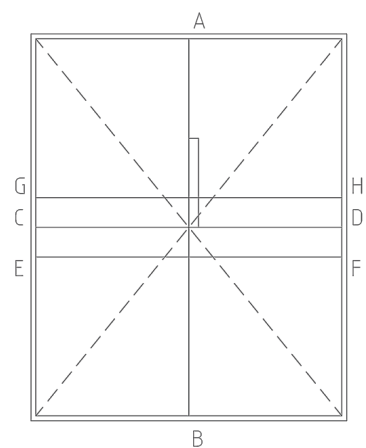

Diagram 5

Installation

The floor should be divided into workable sections, leaving the perimeter tiles unadhered until the main body of the floor has been laid.

Please ensure the correct adhesive spread rate is used which is generally 4 – 5 square metres per litre. Use a 1.6mm x 1.6mm "V" shaped notched trowel. Never use a worn trowel as this will prevent the correct amount of adhesive being applied.

A 95% adhesive transference to the back of the tile is required.

Only spread an area that can be laid in 30 – 35 minutes at 23°C and reducing this time as the temperature increases.

Allow the adhesive to develop some initial tack which will be between 5 – 10 minutes depending on the temperature and humidity at the time.

All Kenbrock planks and tiles are cut with a 23° chamfer in order to minimise visible joints. Be careful not to butt the tiles or planks too tightly as this could cause one end to ride the other causing a lipping effect.

Place the first plank so that its length is running down the A-B line, with its tail butting the C-D line—as shown. Press down on the centre of the plank and run your hand around the edges ensuring that all air is expelled.

Place the second plank on the other side of the A-B line with its nose butting the G-H line as shown.

Proceed down the centre line in one direction laying two planks wide i.e. one plank either side of the centre line. Then revert to the centre and complete the process in the opposite direction.

Lay the third row to complete the three-row sequence. Place a plank alongside row two with its tail on the E-F line. Now complete the third row in both directions.

Repeat the sequence of the three rows until one half of your room is completed.

To commence installation of the second half of the room, place one plank alongside row one with its tail on the E-F line. The next row commences with the plank having its nose on the G-H line with the third row of the sequence starting with a plank having its tail on the C-D line. Extend the rows in both directions.

Continue with three row sequence until the room is completed.

Visually check the completed job and make any necessary adjustments whilst the adhesive is still tacky. At the same time replace any planks or tiles that do not appear perfect.

Clean tools immediately after use with warm soapy water. Remove any adhesive on the surface with damp cloth and broom sweep any grit or debris that could be ground into the surface and cause scratches and damage.

When a section of floor has been laid, excepting the perimeter, the flooring should be rolled in both directions with a minimum 45kg articulated roller.

Prohibit all traffic for 24 hours after the installation is completed to allow adhesive to reach its full bond strength. Do not carry out maintenance during this period and ensure the temperature remains constant between 15 and 28°C.

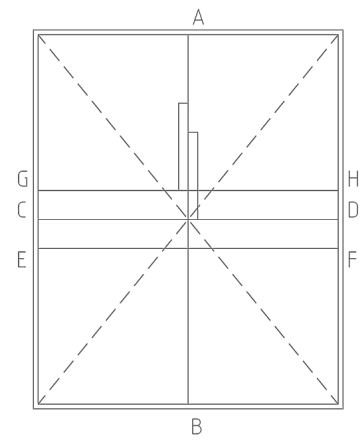

Diagram 6

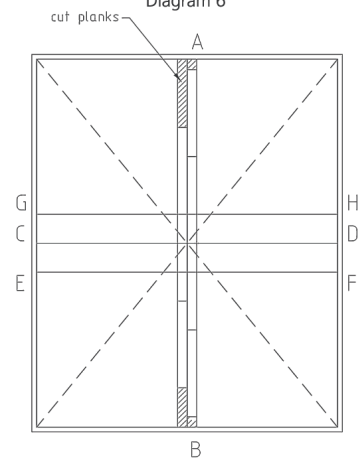

Diagram 7

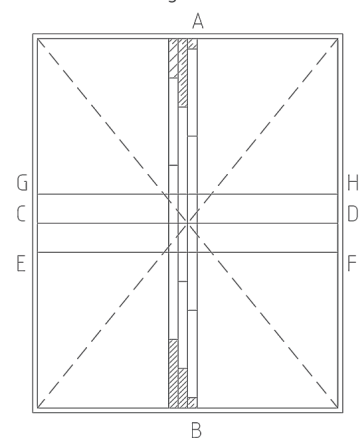

Diagram 8

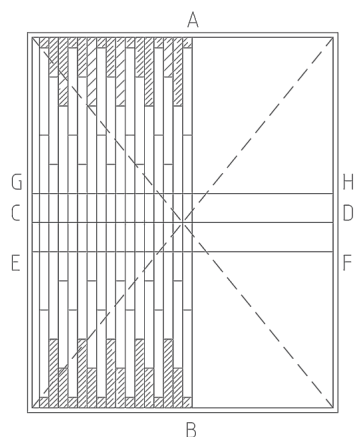

Diagram 9

Cutting Perimeter Plank

Two techniques are commonly used for cutting perimeter planks. The choice is mainly dependent upon the run out of the wall.

Overlapping method:

Use when there is little or no run out of the abutting wall. Plank the plank to be cut exactly over the last laid plank. You may prefer to use matching planks. Place another full plank on top of the tile to be cut with the edge against the wall. Scribe a line into the plank to be cut, using the "bottom edge" of the top plank as a guide. Cut the plank to the scribed line, loose lay into position and check for fit. Repeat along the wall.

Scriber method:

To be used when the wall run out is quite severe or when the wall profile cannot be picked up straight edge. Place the plank to be cut exactly over the last plank laid; ensuring that the pattern match is acceptable. Set the bar scribe to the size of the plank being laid. Trace the profile of the wall onto the plank to be cut, ensuring that the bar scribe is kept upright and square to the edge of the plank. Cut the plank to the scribed line, loose lay into position and check for fit. Repeat along the whole wall.

Once a wall edge had been fitted and loose laid, turn all the edge plank you have cut inward so as not to lose their position. Spread the adhesive right up to the edges. When the adhesive has lost sufficient moisture press the edge planks into position. Wipe away any excess adhesive as work progresses. Roll with 50kg articulated roller.

The floor should be given a second rolling approximately two hours later.

Post-Installation & Maintenance

Allow 24 hours after installation for the adhesive to dry then using a brush, dry cloth or vacuum cleaner for cleaning. Where water/cleaning fluid is required, ensure the minimum is used. Again use window coverings to protect the floor from heat and fading under direct sunlight. Dramatic temperature change of the flooring could cause joints to lip or gaps to occur.

Daily

Mop, sweep or vacuum to remove loose dirt and dust. As required, spot clean with Kenbrock Maintain to remove stubborn marks.

Weekly / Monthly

As required, clean the floor using Kenbrock Maintain, using a sponge or stringy type mop, use an absolute minimum to prevent liquid penetrating into the seams and joints.

The maintenance regime requires the installation of an effective barrier matting system.



Please note that Kenbrock does not warrant for fading caused by long term exposure to UV light sources, it is recommended that any areas subjected to this direct exposure be protected by curtains, blinds or tinting to reduce the intensity of the ultra violet light.

Kenbrock also does not warrant gapping caused by structural or subfloor movement, or any gapping that may be caused by extreme changes in temperature.